

FOOD WARMING/MERCHANDISING CABINET



MODEL 995 STEAM TABLE

The Model 995 Warmer/Merchandiser provides an ideal environment for promoting and preserving the freshness of soft pretzels, breaded products, vegetables, and other foods that require heat and humidity. Food is kept fresh and warm by moist air that is continuously circulated throughout the cabinet. Curved glass display and mirrored doors maximize product visibility.

FEATURES:

- (2) 75-watt Teflon coated light bulbs
- 22-gauge stainless steel base
- glass sides
- mirrored sliding glass doors

OPERATION:

The unit incorporates heat and humidity to hold product for maximum length of time. Air is moved throughout the cabinet by means of a fan, circulating the air over heated water pans in the bottom of the display case. (See back page for installation)

CAPACITY:

Two 2-1/2" deep (63.5mm) full size steam table pans. (Pans not included)

SPECIFICATIONS:

21" H, 31" Front to Back including control box
30-1/2" Right to Left
(see additional information on the back of this page)

ELECTRICAL:

120 Volts, 1500 Watts, 12.5 Amps
60Hz single phase, with 6 foot grounded power cord

SHIPPING WEIGHT: *Must ship via freight truck
The unit is palletized and shrink wrapped to the pallet.
Shipping wgt. Is 180 lbs. and the shipping dimensions are 48" x 42" x 30"



An ISO 9001 Company

FP140033-M
02/10

WISCO INDUSTRIES®

P.O. BOX #10
OREGON, WI 53575
PHONE: 608-835-3106
FAX: 608-835-8273
www.thepizzaoven.biz

LIMITED WARRANTY:

Wisco Industries, Inc. expressly warrants the product will be free from defects in workmanship and materials for a period of 1 year from the date of shipment. WISCO DISCLAIMS AND EXCLUDES ANY AND ALL OTHER EXPRESS OR IMPLIED WARRANTIES, INCLUDING WITHOUT LIMITATION, ANY AND ALL WARRANTIES OF MERCHANTABILITY OR FITNESS FOR A PARTICULAR PURPOSE.

Buyer agrees that its SOLE AND EXCLUSIVE REMEDY against Wisco and Wisco's SOLE AND EXCLUSIVE LIABILITY arising out of any defect or nonconformity in the product shall be replacement/exchange of such nonconforming countertop food service equipment at Wisco's expense. No countertop food service equipment shall be returned without Wisco's consent. IT IS AGREED THAT WISCO'S MAXIMUM LIABILITY SHALL NOT IN ANY CASE EXCEED THE SALE PRICE FOR THE COUNTERTOP EQUIPMENT CLAIMED TO BE DEFECTIVE OR NONCONFORMING.

MODEL 995 Heated Display Cabinet

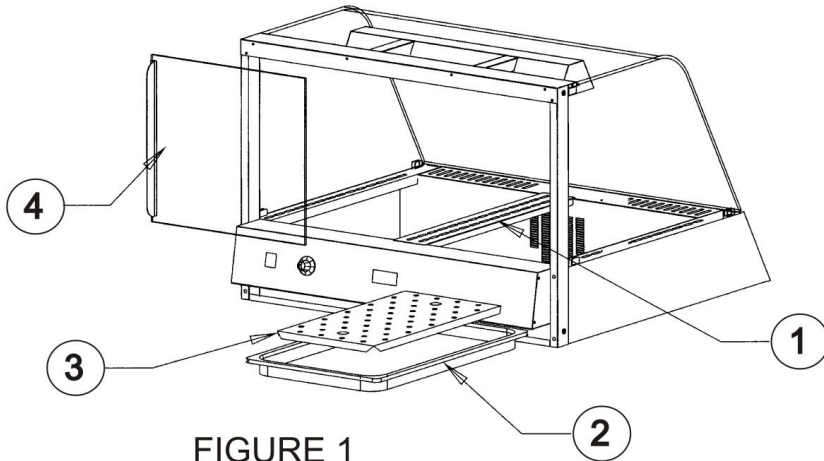

FIGURE 1

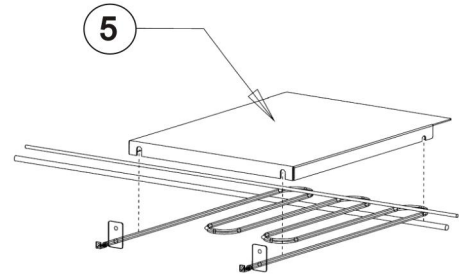

FIGURE 2

GENERAL INFORMATION

The heated display case attractively displays your food products and maintains them at ready-to-eat temperatures. A convection fan circulates heat throughout the entire display cabinet. Water trays extend food holding items by reducing moisture loss. Sliding glass doors help retain heat while providing access to the food.

ITEM	PART NO.	DESCRIPTION	QTY
1	0018779	Pan Divider	1
2	0018778	Water Pan	2
3	0018754	Baffle (water pan)	2
4	0018758	Door Assembly	2
5	0018720	Heat Shield	2

INSTALLATION

1. Remove all packaging materials.
2. Remove, wash, and dry water pans, baffles, heat shields and the center pan divider.
3. Wipe all surfaces with damp cloth.
4. Wipe the glass surfaces, inside and out, with a clean cloth.
5. Place baffles (#3) inside water pans (#2) and slide in place through bottom opening in back of unit (Fig.1).
6. Position heat shields (#5) on elements (Fig.2). Shields rest on elements and large support rod.
7. Place unit on a sturdy, level table or other work surface. Unit should be placed near an electrical outlet so the power cord is not stretched or strained.

TO INSTALL DOOR:

1. Carefully place the top of each door assy (#4) into the upper plastic channel.
2. Allow the door to rest on the lower plastic channel.

OPERATION

1. Slide water pans out and fill with clean tap water. Fill with 4 qts. (3.8 liters) each.
2. Carefully slide pans completely back into cabinet, avoiding any spillage into the unit.
3. Turn power switch on.
4. Set thermostat to desired temperature.
5. Slide the rear glass doors open and load the serving pans with product using tongs or similar utensil.
6. Close the rear sliding doors.

SPECIFICATIONS

Dimensions: 31"L x 30.5"W x 21"H

Electrical: 120 Volts, 1500 Watts, 12.5 Amps 60Hz, Single Phase, with 6 ft. Grounded power cord

Food Capacity: (2) 2-1/2" (63.5mm) deep full size steam table pans

Water Capacity: (2) water pans; 4 qts. (3.8 liters) each

WISCO INDUSTRIES INC.**REPAIR PARTS FOR MODEL 995**

<u>ITEM</u>	<u>PART NO:</u>	<u>DESCRIPTION:</u>
1)	0018751	SIDE GLASS
2)	0018758	DOOR ASSEMBLY
3)	0017354	THERMOMETER
4)	0017248	THERMOSTAT
5)	0017274	THERMOSTAT KNOB
6)	0016119	ON/OFF SWITCH
7)	0018778	WATER PAN
8)	0018784	BAFFLE (WATER PAN)
9)	0016418	LIGHT SOCKET ASSY
10)	0018708-7	HEATING ELEMENT
11)	0018757	FRONT GLASS ASSY
12)	0018795	BLOWER ASSY
13)	0018719	LIGHT BULB
14)	0018756	DOOR HANDLE
15)	0018781	DOOR TRACK (UPPER)
16)	00448	CORD
17)	0016024	STRAIN RELIEF
18)	0018780	LOWER DOOR TRACK
19)	0018779	PAN DIVIDER
20)	0018720	HEAT SHIELD
21)	0018760	FRONT PANEL
22)	0018749	CONTROL PANEL
23)	0018710	SUPPORT ROD (HEATING ELEMENTS)